

One way (multiple) moving cabinets installation instructions

1.Profile introduction

Track	Moving Track	Channel steel
		

2.Door panel view

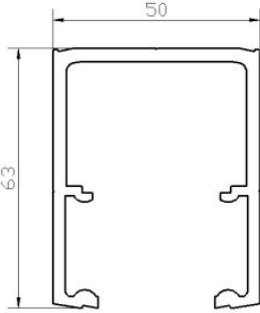
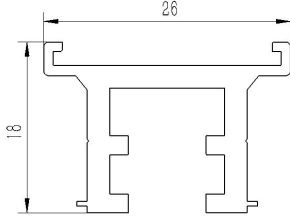
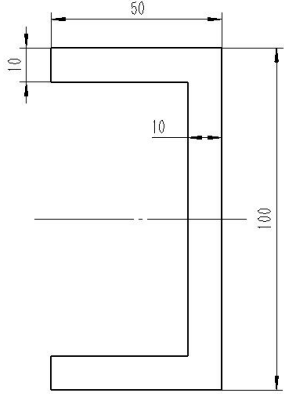
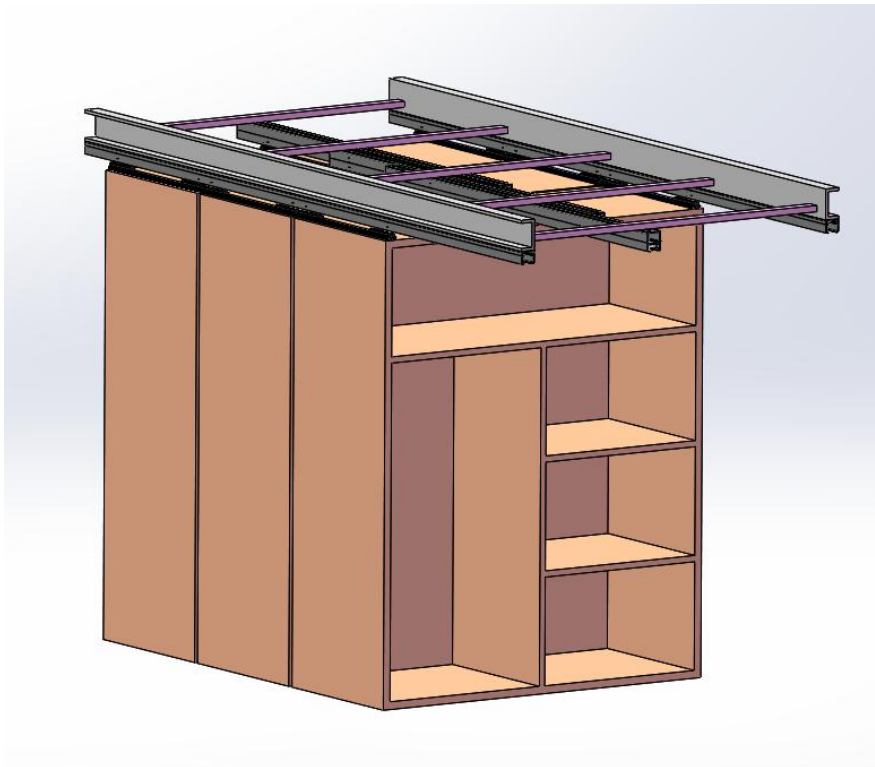

One way moving cabinets

3 .Accessory

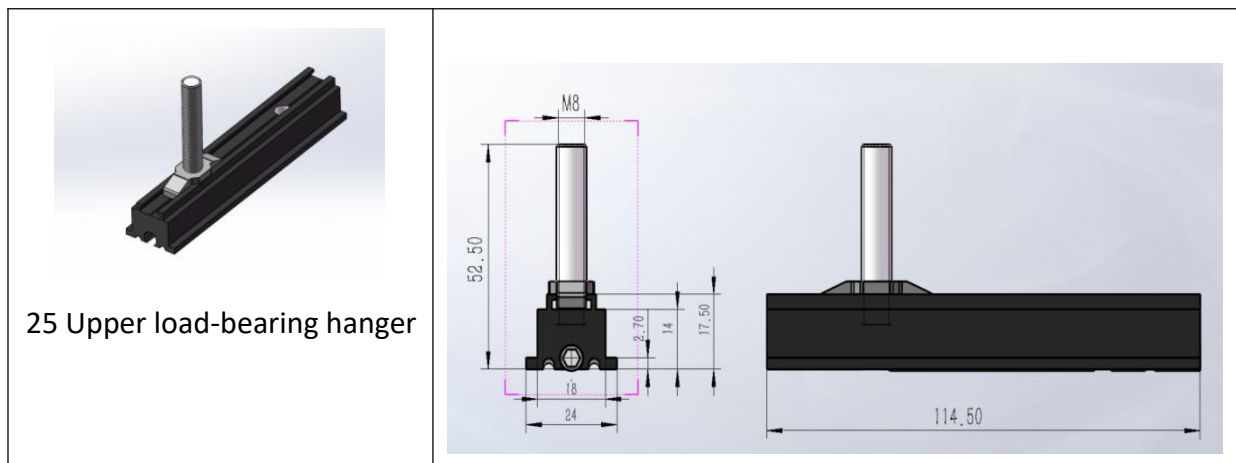



25 Base

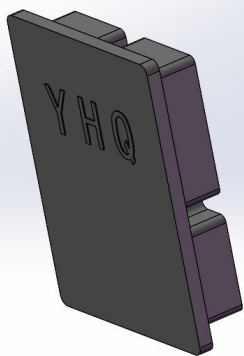
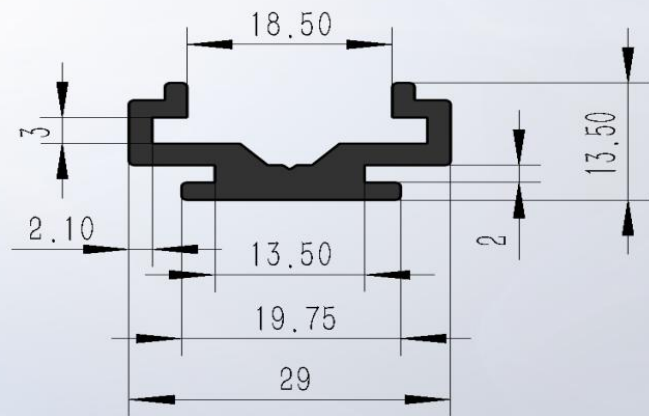

Track end cover

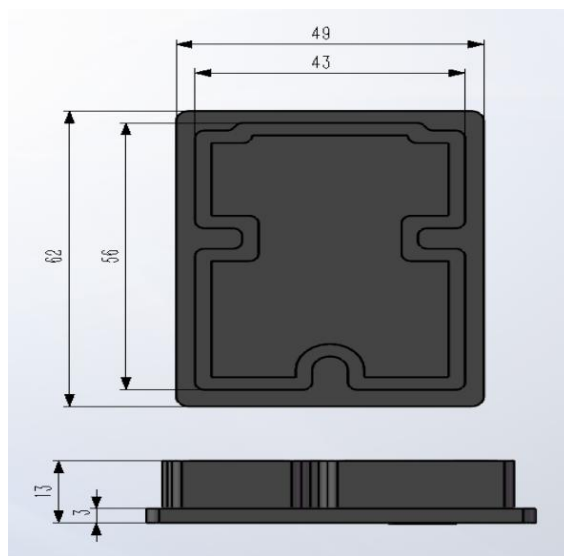

4. Installation mode

Top installation diagram

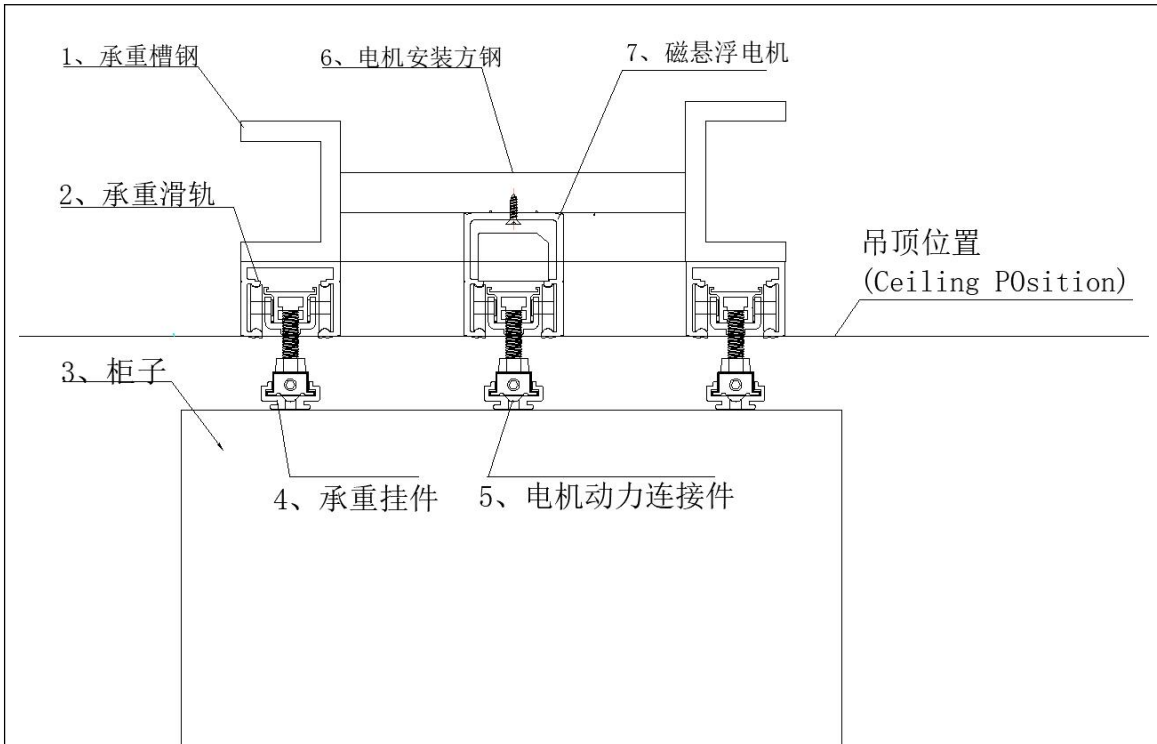

1-Load bearing channel steel 2-load bearing moving track 3-cabinet 4-Load bearing pendant
5-Motor connection 6-Motor installation square steel 7-Magnetic Levitation motor

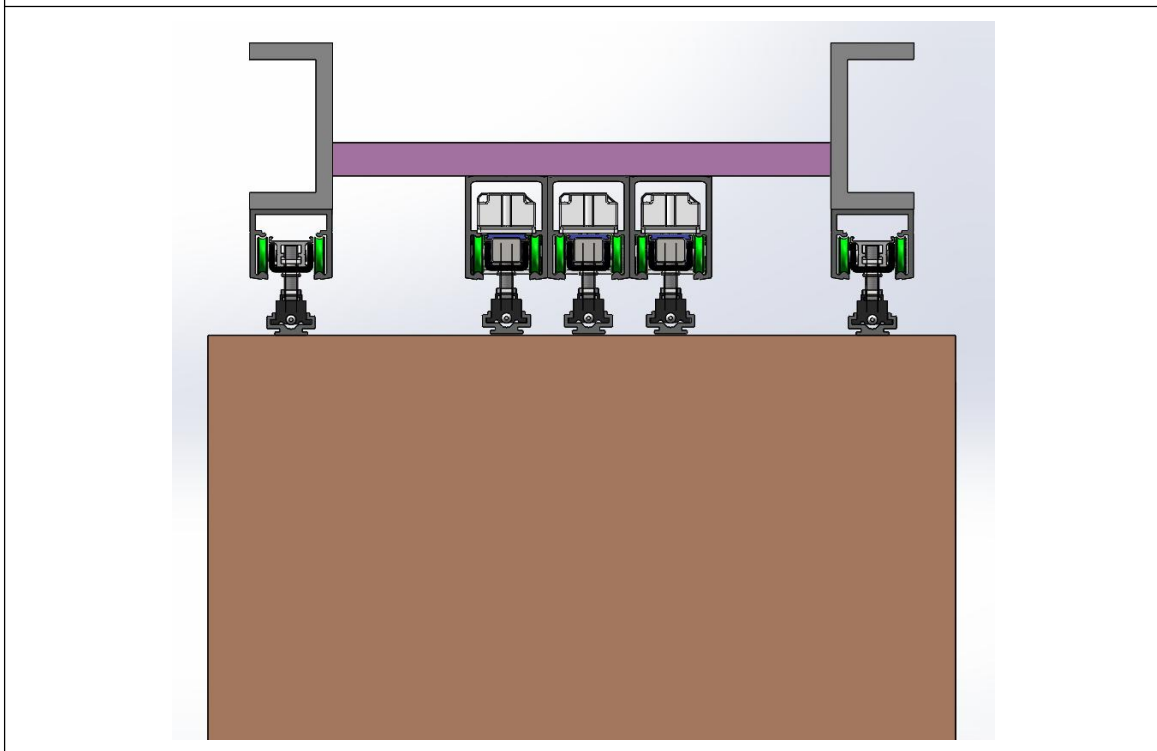

5,Installation diagram

One way moving cabinets

